

Note:  
Front intake optional

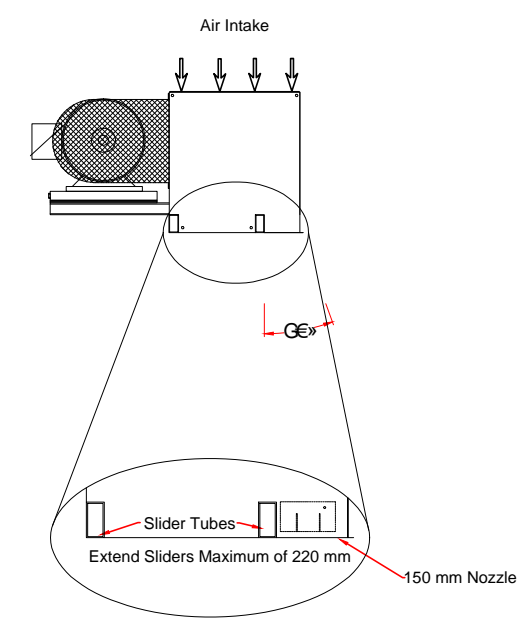
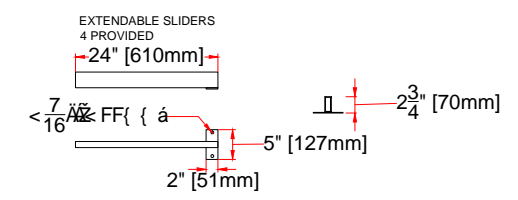

CE CERTIFIED

<p>ENERSHIELD EUROPE</p> <p>Calderhead Road</p> <p>Shotts, Lanarkshire, Scotland</p> <p>Tel.+44(0)1501 826501 FAX+44(0)1501 826501</p> <p>E-mail: enquiries@enershield.eu</p> <p>www.enershield.eu</p>	<p>ENERSHIELD AIR BARRIER</p>			<p>Xtremeshield</p> <p>XS-120</p>
	<p>VOLTAGE</p> <p>400/690V 3phase 50 Hz</p>		<p>Blowers</p>	<p>Air Velocity (fpm) (m/s)</p> <p>7500/38.1</p>
	<p>Motor (s)</p> <p>1 @ 11 Kw 21.2/12.3 Amp</p>		<p>4</p>	<p>Air Volume (cfm) (l/s)</p> <p>41,720/19,680</p>
				<p>Total Kw</p> <p>11</p>
				<p>Weight lbs/Kg</p> <p>900 / 410</p>