

Vertical or High Lift OH Door Shown  
Consult Factory for standard lift door installations

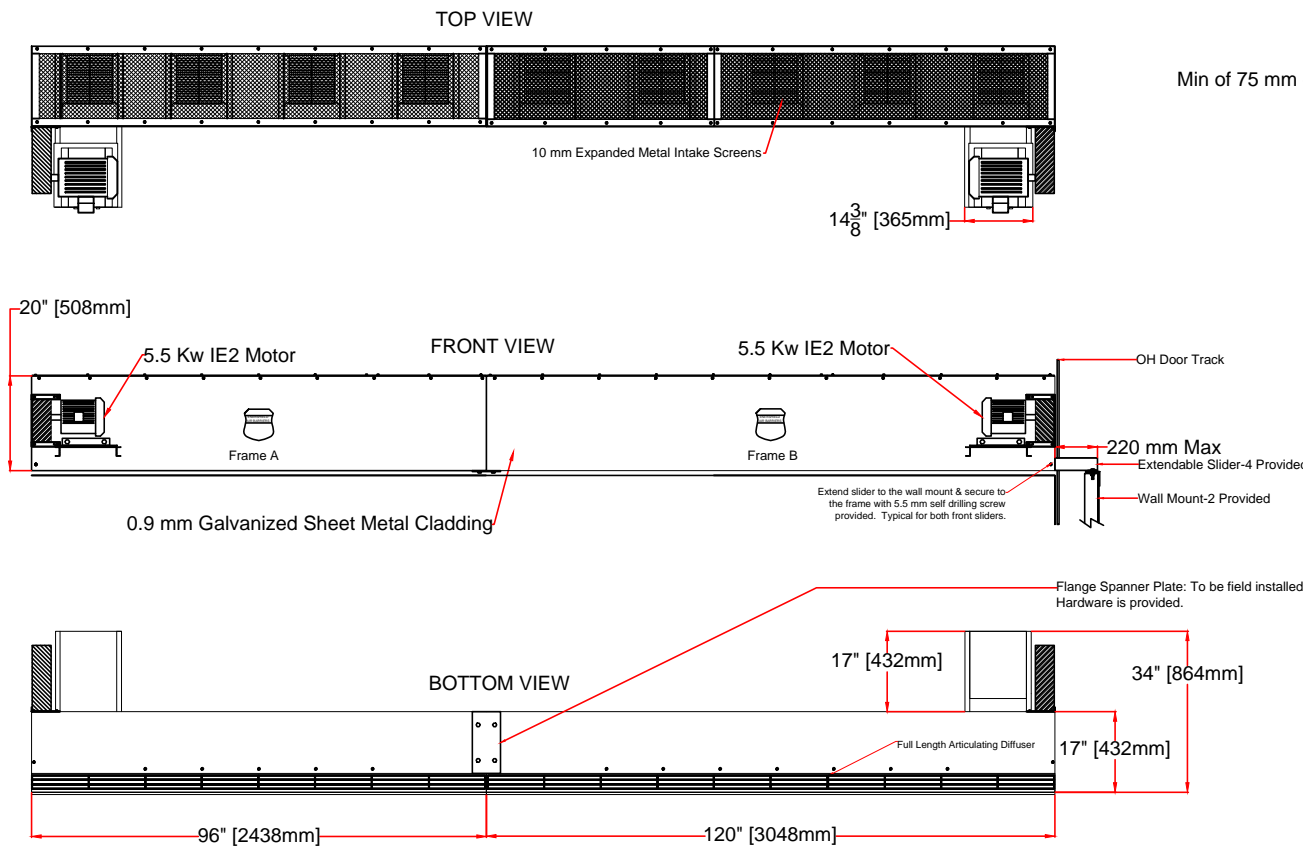

Min of 75 mm clearance between barrier and open door. Door not shown.

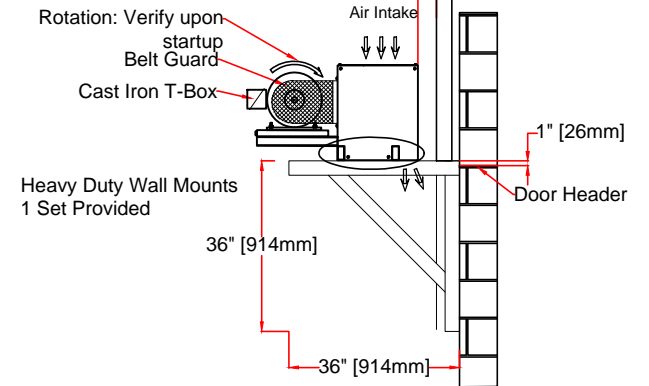

Field drill 13 mm holes into the wall mount and bolt sliders with the 12 mm hardware provided

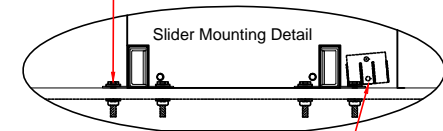

Adjust the diffuser 10-15 degrees towards the exterior of the building. Confirm diffuser adjustment after power has been supplied to the Air Barrier. See owners manual.

CE CERTIFIED

ENERSHIELD EUROPE

Calderhead Road

Shotts, Lanarkshire, Scotland

Tel.+44(0)1501 826501 FAX+44(0)1501 826501

E-mail: enquiries@enershield.eu

www.enershield.eu

## DURASHIELD-HD

Voltage  
400/690v/3ph/50Hz

Motor(s)  
2 @ 5.5 Kw, 1460 RPM, IE2,  
IP55, VFD Compatible  
10.5/6.09 amp each motor  
21/12.18 amp total

Blowers

9

DURASHIELD-HD

DSH-216

Air Velocity (fpm) (m/s)

5500/27.9

Air Volume (cfm) (l/s)

29,025/13,680

Total Kw/watts

11Kw/11,000 W

Weight lbs/Kg

1188 lbs/540 Kg