

Vertical or High Lift OH Door Shown
Consult Factory for standard lift door installations

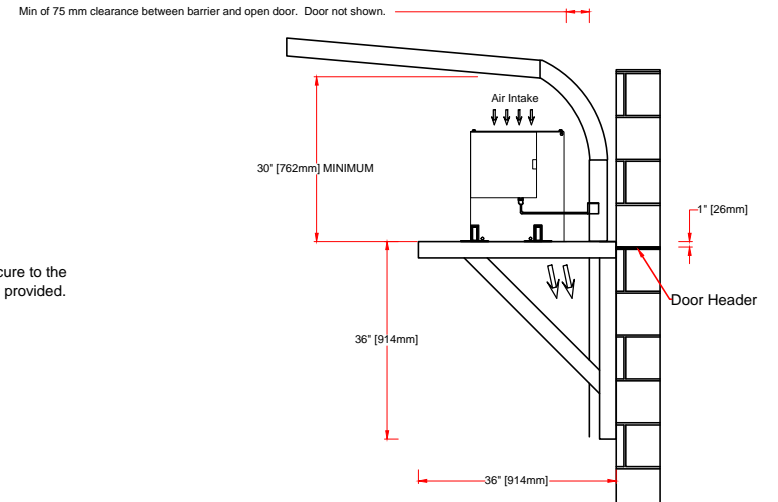

Slider Mounting Detail

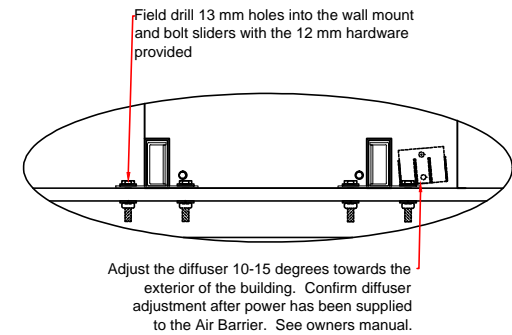

CE Certified

ENERSHIELD EUROPE

Calderhead Road

Shotts Lanarkshire Scotland

Tel.+44(0)1501 826501 FAX+44(0)1501 826501

E-mail: enquiries@enershield.eu

www.enershield.eu

ENERSHIELD AIR BARRIERS

VOLTAGE 230/ 1 / 50			Blowers 6
Motors 6 @ 0.35 Kw Total 2.1 Kw 2.83 amp ea- FLA 16.9 Total			DATE ORDERED
			DATE SHIPPED

Model DURASHIELD	Model # DS-144
Air Velocity (fpm) (m/s)	4500/22.9
Air Volume (cfm) (l/s)	16,950/8000
Total Kp/watts	2.1/2100
Weight lbs/Kg	515lbs/234Kg

Project:
Engineer:
Tag: